

# WATER ON THE WATER®

K5 [Marine / R.V.]  
Drinking Water Station



 **Kinetico®**  
marine water systems

- ▶ Maximum Water Efficiency
- ▶ No more carrying bottled water on board
- ▶ Protection against a wide variety of contamination
- ▶ Flexible and Expandable to meet any drinking water need
- ▶ Flow from your faucet is up to two times greater than with any other drinking water system
- ▶ Draw from shore water, fresh water holding tanks, or in certain applications directly from the lake

# What Makes The Kinetico K5 Marine / RV Drinking Water Station Different?

1. **Cartridge Options.** Eight different options to meet your removal needs now and in the future. Includes the Purefecta Bacteria/Virus Guard for Microbiologically pure water. The Mineral Plus cartridge improves the taste and health benefits of water. Cartridge also available for arsenic, chloramines, chlorine/sediment, perchlorate and VOC reduction. Final polish with carbon post filter.
2. **QuickFlow Technology.** Delivers a strong flow of water from the faucet. Allows system to produce more water in less time.
3. **High Daily Production.** Can produce more than 40 gallons per day.
4. **Quick Disconnect Sanitary Filter Cartridges.** Makes changing filters easy.
5. **Patented, Exclusive EverClean® Rinse.** Consistently-high water quality. Increases membrane life - lowers maintenance cost.
6. **PureMometer® Filter Life Indicator.** Shows filter capacity.
7. **Patented, Tamper-Proof MACguard® Filter.** No more wondering when to change cartridges. Assures high quality water and peace of mind.
8. **Automatic System Shutdown.** Conserves water - doesn't run water continuously to drain.
9. **Exclusive Designer Faucet.** Lead-free, stylish design available in a variety of finishes.
10. **Non-Electric, Totally Automatic.** No electrical problems.
11. **Efficient Operation.** Conserves water, lower operating costs.
12. **Outstanding Warranty.** Dependability, peace of mind.

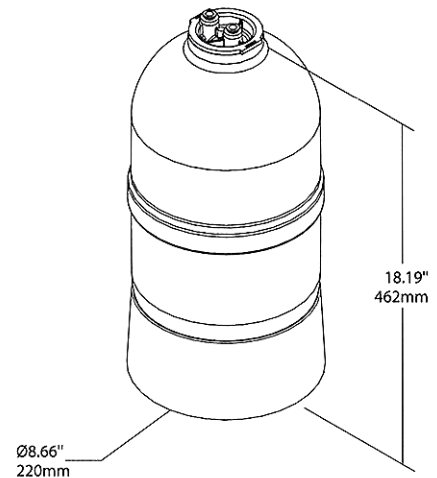
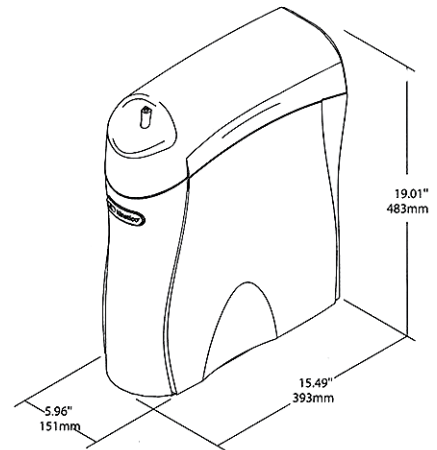

## Third-Party Certification

The majority of Kinetico products are certified by third party labs such as NSF and WQA. To further ensure consumer confidence, several of our models are certified by two or more of those independent labs, which is unprecedented in the industry. For specific claims and certifying labs, refer to performance data sheets or consult your local Kinetico dealer.

\* information on the performance characteristics of Purefecta® can be found at [www.epa.gov/etv](http://www.epa.gov/etv) or call 1.440.564.9111 for a copy of the ETV verification report. Use of the ETV name or logo does not imply approval or certification of this product nor does it make any explicit or implied warranties or guaranties as to product performance.



For details contact:

**Mark Godfrey**  
Product Support Technician

Tel: 705 327 0013

Fax: 705 326 9305

Toll: 800 667 8420

Cell: 705 623 1607

## The Water market

7 Colborne St. East  
Orillia, ON L3V 1T4  
[www.thinkclearblue.ca](http://www.thinkclearblue.ca)

